



HANGCHA GROUP CO., LTD.

Factory site: 666 Xiangfu Road, Hangzhou, Zhejiang, China (311305)

Tel: +86-571-88926735 88926755
Fax: +86-571-88926789 88132890

sales@hcforklift.com
www.hcforklift.com



Follow us on Facebook



Follow us on YouTube



Follow us on WeChat



Download "Hangcha Forklift" App



ISO45001:2018



ISO14001:2015



ISO9001:2015



HANGCHA trucks conform to the European Safety Requirements.

2025 VERSION 2/COPYRIGHT 2025/05

HANGCHA GROUP CO., LTD. reserves the right to make any changes without notice concerning colors, equipment, or specifications detailed in this brochure, or to discontinue individual models. The colors of trucks, delivered may differ slightly from those in brochures.

A Series Premium Version Reach Truck

with capacities of 1,200 to 2,000kg



INNOVATIVE LITHIUM-ION

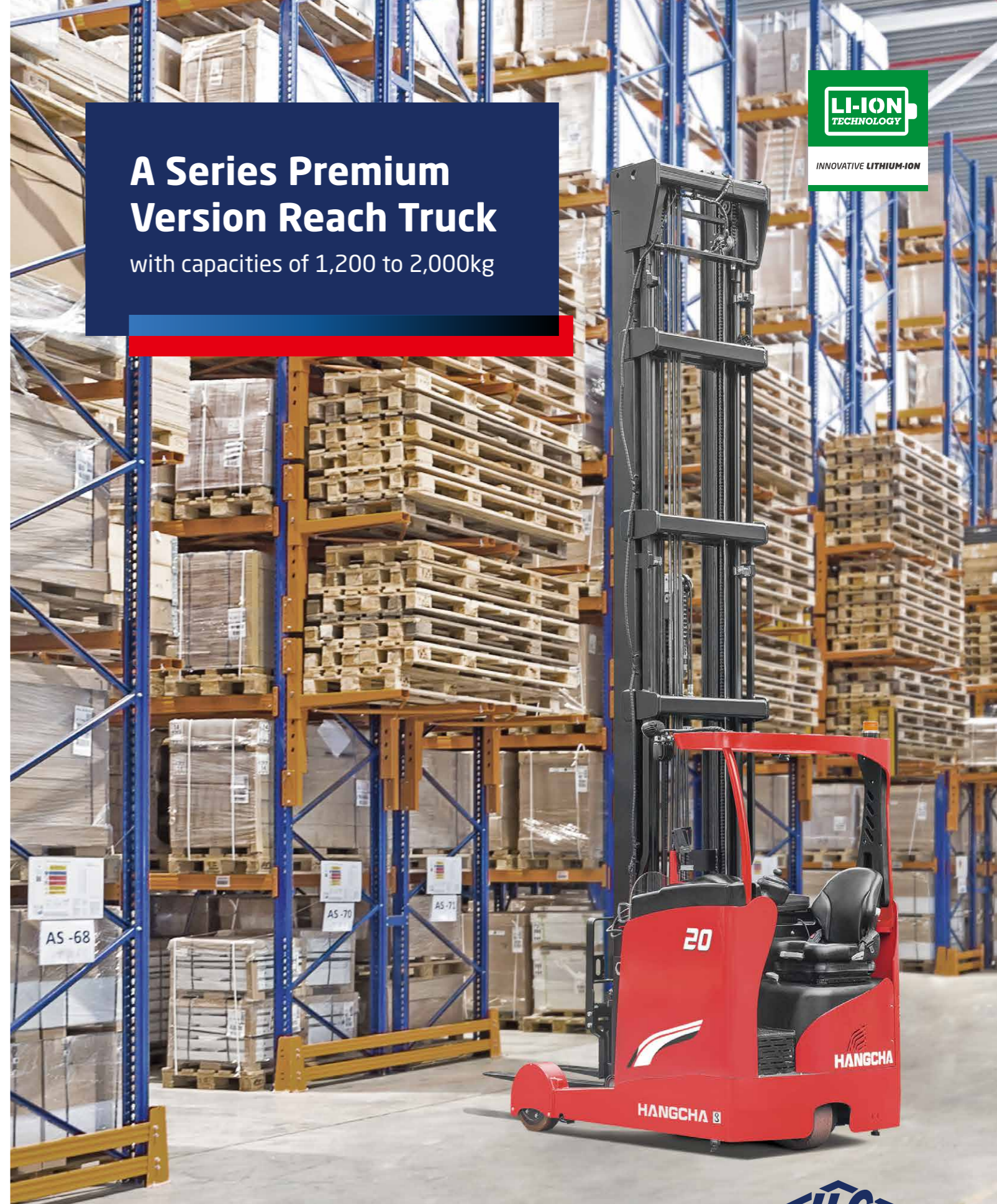

The World of Hangcha
SINCE 1956





REACH TRUCK ADVANTAGES



10 reasons choose A series reach truck

- ▶ **APPEARANCE-** Beautiful / Compact / Ergonomic
- ▶ **HIGH PERFORMANCE-** Transmission system / Motor
- ▶ **RENEWABLE ENERGY TECHNOLOGIES-** Hydraulic system
- ▶ **PERFECT RESIDUAL LOAD CAPACITY-** Mast system
- ▶ **FLEXIBILITY-** Steering system
- ▶ **EXCELLENT ERGONOMIC & COMFORT-** Fingertip system
- ▶ **ADVANCE-** INMOTION control system
- ▶ **VISIBILITY-** Overhead guard
- ▶ **RELIABILITY-** Plastic oil tank / Braking system
- ▶ **MAINTENANCE-** Battery side roll-out

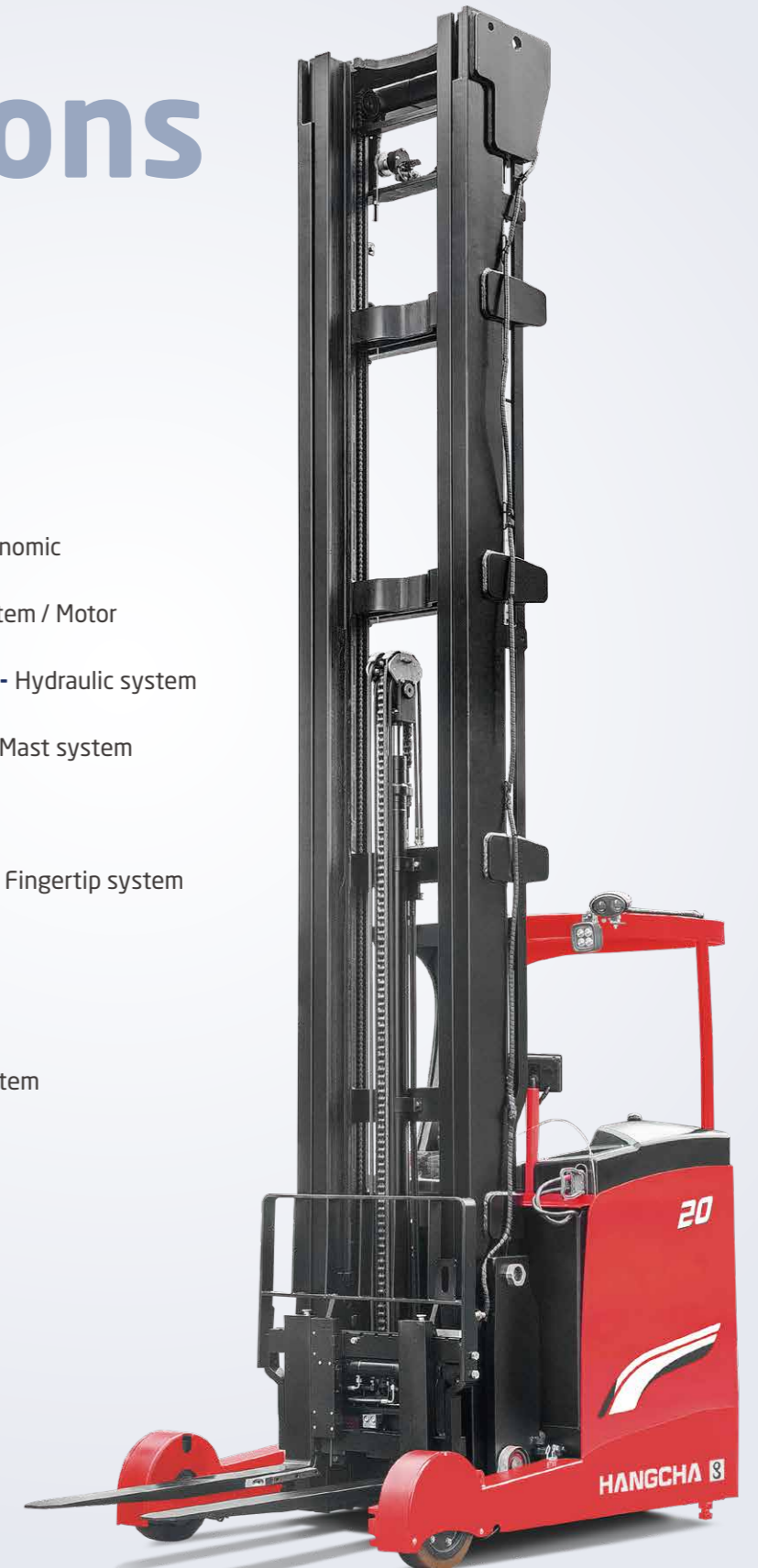

A SERIES PREMIUM VERSION REACH TRUCK

After several years of design, development, and manufacturing, Hangcha launched a new product lately -the A Series Premium Version Reach Truck:

CQD12/14/16/20-AD2H. This truck is mainly used in multi-level warehouse.

CQD20-AD2H rated load capacity is 2 tons, maximum lifting height is 12.5m, and the load capacity can reach 1100kg at the maximum lifting height. Its technical parameters and configuration are close to that of similar products of international manufacturers including Crown, Linde, Jungheinrich, and Hyster. This product (A series premium version reach truck) together with standard reach truck constitute the entire family of A Series reach truck of Hangcha. These products supplement with each other in rated tonnage, cover different prices together, and can satisfy different demands in prices, functions, and configuration from various users.

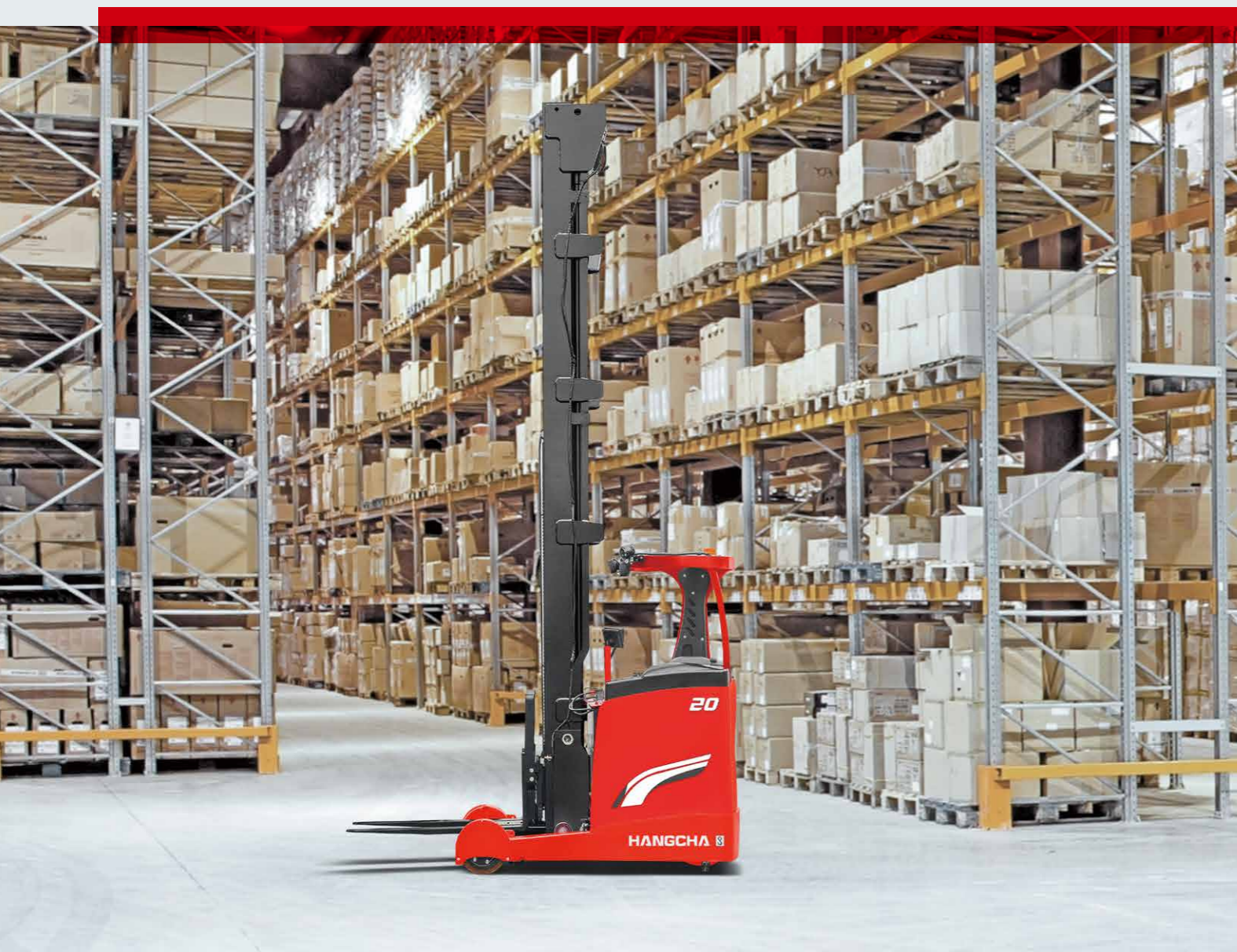

APPEARANCE

Top appearance design teams from Europe and China are engaged to carry out brand-new optimized design for this product. It features beautiful appearance and European design elements, excellent ergonomics and man-computer interaction functions, and inherits appearance elements of A Series electric trucks.



Overall Ergonomic Design



Overall Appearance Design

HIGH PERFORMANCE

The drive system includes the ZF® gearbox imported from Germany with original packaging, the imported Schabmuller® AC drive motor, and the Schabmuller® electric steering motor, with excellent performance, as well as drive system, AC motor, EPS (Electric Power Steering) system, and electromagnetic braking system of same configuration as that of imported brands such as Jungheinrich, Hyster, and other leading manufacturers.

All core parts are ZF products imported from Germany.

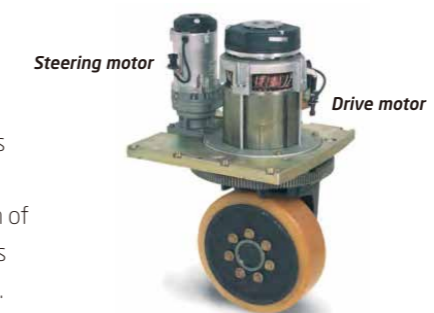



PERFECT RESIDUAL LOAD CAPACITY

The mast system is made of imported steel channels, and new optimized design is applied for the carriage system, which thoroughly eliminates the problem of shaking and large gap that are detected in previous home-made masts, effectively improves residual load capacity, and increases load capacity reducing height. Maximum lifting height is 12.5m, and load capacity can reach 1100kg at the maximum height.

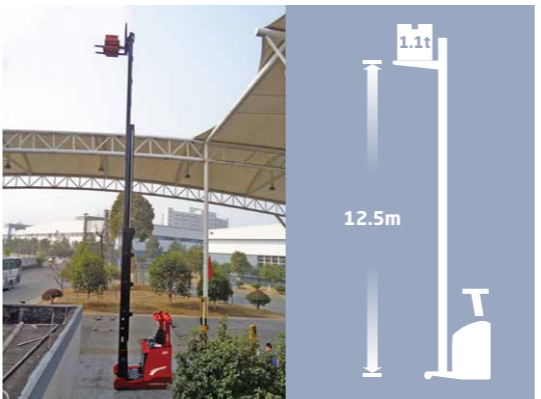

Maximum 12.5m, lifting 1.1t

Automatic select height level function is also optional for the mast system, which can pre-select height automatically according to height of the user's shelf, and the forks lifting will slow down and stop when required height is reached. It is very convenient for stacking work, and can reduce labor intensity and psychological burden of the operator significantly.



Optional: Preset level selection function

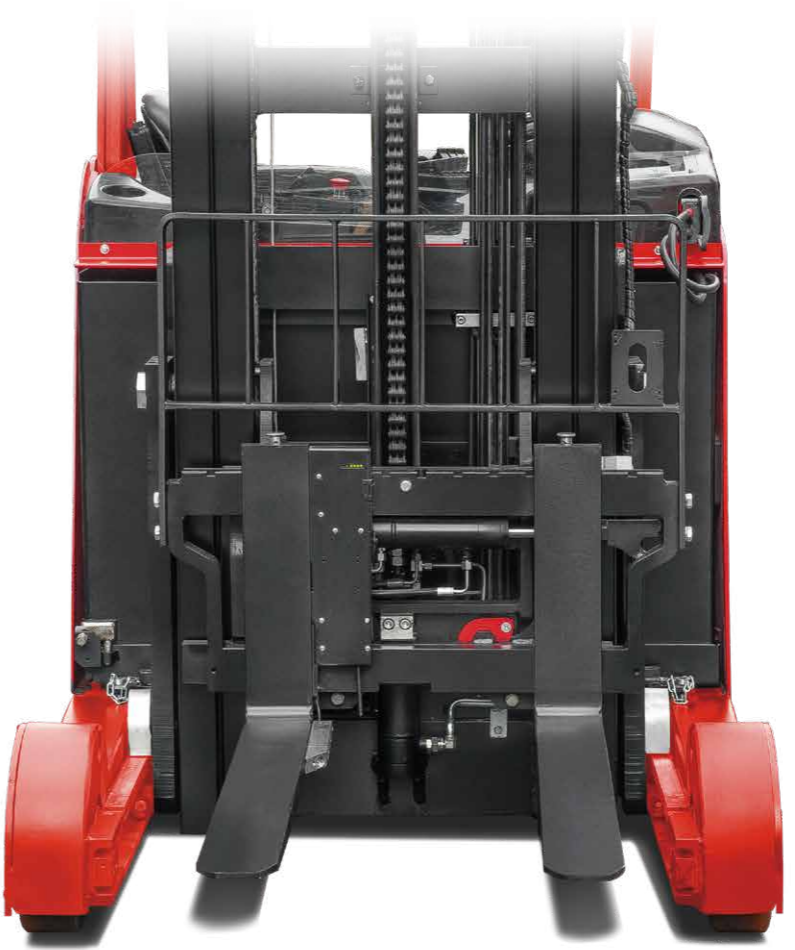

Optional: Camera system

The user can choose camera system and height indicator to facilitate operations at elevated location.



FLEXIBILITY

Electric Power Steering(EPS) system is a standard configuration, which can be switched between 360-degree and 180-degree operations according to habit of the user. The upgraded EPS system effectively avoids the impact of hydraulic control, can reduce fatigue of the operator, and its minimum steering force can reach 3N (that of regular forklift is about 10N).

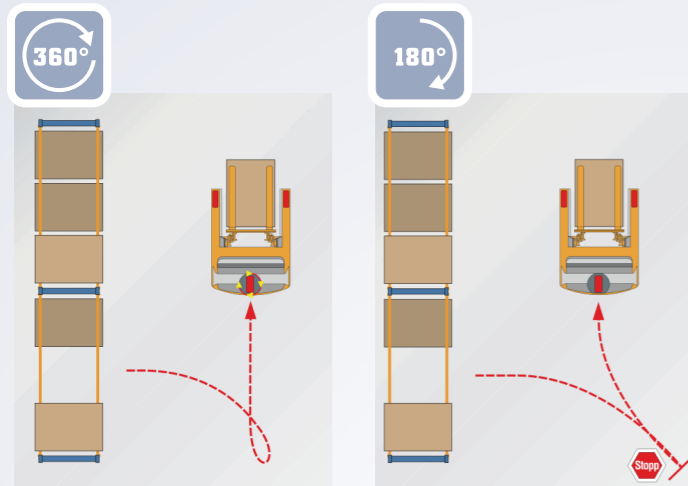

In the mode of 360-degree steering, when steering exceeds 270 degree, the reverse is switched to forward director, no reversing is required, and the truck is switched to advance automatically, no parking is required, with higher efficiency.

In the mode of 180-degree steering, the truck must be reversed until it stops completely, and the direction must be switched before the truck can travel forward, with lower efficiency.



Whichever of above two modes the operator wants to select, there has a button for switching operation to activate the mode required, which can be selected freely by the operator according to his/her habit. The electric steering wheel is small and light. The operator can adjust it by moving backward or forward to find a suitable position. The steering wheel have built-in damper, with reliable signal transmission of stepping motor.



- ▶ **Drive wheel automatic centering function**
- ▶ **Automatic limit on speed and accelerated speed when steering**



EXCELLENT ERGONOMIC & COMFORT

Fingertip system is a standard feature for the truck (with imported SAUER-DANFOSS hydraulic valve), with four finger control functions of lifting/lowering, mast forward and backward movement, tilt, and sideshift, and seven major functions including direction switching, emergency power off and horn. It offers comfortable operation for operator, with soft armrest. The fingertip system communicate by CAN Bus system, which is reliable and fast. The armrest can be adjusted forward and backward, fingertip system enables more accurate control than mechanical valve.



Fingertip system integrated control system, with good man-machine function



Cutting-edge SAUER-DANFOSS electromagnetic multi-way valve imported from Germany. With potential energy recovery switching function(optional)

ADVANCE

The truck is equipped with 4 INMOTION controllers, drive controller, oil pump controller, steering controller and valve controller, all controllers communicate by CAN Bus system. Controllers have advanced program and outstanding control strategy (same as that of imported trucks). All core parts are imported or of joint-venture brands, with reliable quality. The entire truck is equipped with waterproof connectors.



Fully-open pedal structure, electrical parts are fully exposed, which is convenient for maintenance



VISIBILITY

The overhead guard enables panoramic visibility. There are two pieces of tempered glass of 25mm thickness on top of the overhead guard, which is infilled with glue, offering excellent impact resistance. The visibility above the operator is incomparable and excellent, with reduced psychological burden for the operator.



Optional: Overhead guard with panoramic glass offers excellent visibility for elevated location.

RELIABILITY

The LLD PE plastic oil tank, which increases quality and cleanness of oil effectively, together with hydraulic filter element from German HYDAC, providing much higher cleanness of entire hydraulic system. The oil tank features large volume, fast heat exchange, together with electronic fan within the housing, achieving thermal equilibrium quickly of hydraulic oil at most suitable working temperature.

The reach truck is equipped with electromagnetic braking system, including three separate brakes, two sets of MARTIX electronic drive brake imported from UK, and one set of INTORQ Electric Parking Brake system from Germany. Braking force is proportional to depth of electronic pedal, the braking performance is gentle and reliable.



MAINTENANCE

DIN standard battery is a standard configuration with capacity up to 48V/ 600Ah, and the maximum capacity available as an option is 775Ah, with powerful endurance. Battery side roll-out is a standard feature, which is convenient for maintenance.



Standard configuration: Battery side roll-out + trolley(optional)



Options

- / 5.0~12.5M full free triplex mast is made of imported steel channels
- / Camera system
- / Height level selection/ Fork height display
- / OPS system
- / Panoramic glazed overhead guard
- / Big capacity battery according DIN STD
- / Various length forks
- / Drive in rack overhead guard
- / GRAMMER MSG531 seat

Standard specification

- / SCHABMULLER AC traction motor
- / SCHABMULLER AC steering motor
- / HEPU AC pump motor
- / Electric Parking Brake (EPB) system
- / Load wheel adopts electromagnetic proportional braking technology
- / INMOTION control system
- / Real-time shifting between 360°steering mode and 180°steering mode
- / Electric Power Steering (EPS) system
- / GRAMMER Fingertip system
- / PU tyre
- / LED headlamp
- / Alarm lamp
- / 4 modes power selection
- / 5M full free triplex mast
- / SAUER-DANFOSS 4 spools control valve

- / Load backrest
- / PE LLD material oil tank
- / Imported lower noise gear pump
- / Energy regenerating during deceleration
- / Battery side roll-out
- / Buffering on lifting limit
- / Soft landing system
- / Blue spot
- / Automatic limit on speed and accelerated speed when steering
- / Lift top buffering (Triplex mast)
- / Mast move forward/backward buffering
- / Automatic speed reduction when the mast lifting high position (Triplex mast)

Battery Option

	460Ah	500Ah	560Ah	600Ah	620Ah	750Ah	775Ah
1.2/1.4/1.6t	●	○	○	○	○	x	x
2.0t	x	x	x	●	○	○	○

Note: ● Standard ○ Optional x Can not choose

Li-Ion Battery Pack specification

Type		CQD20-AC5H-1*
Li-Ion battery	V/Ah	51.52/500

Note: * CE model



A SERIES PREMIUM VERSION REACH TRUCK

Distinguishing mark	HANGCHA GROUP CO.,LTD.						
	1.1	1.2	1.3	1.4	1.5		
1.1	Manufacturer						
1.2	Manufacturer's type designation	CQD12-AC5H*	CQD14-AC5H*	CQD16-AC5H*	CQD20-AC5H*		
1.3	Drive: electric (battery or mains), diesel, petrol, fuel gas	Electric	Electric	Electric	Electric		
1.4	Operator type: hand, pedestrian, standing, seated, order-picker	Seated	Seated	Seated	Seated		
1.5	Rated capacity/rated load	Q (kg)	1200	1400	1600	2000	
1.6	Load centre distance	c (mm)	600	600	600	600	
1.8	Load distance, centre of drive axle to fork	x (mm)	269	269	269	344 ¹⁾	
1.8.1	Load distance, centre of drive axle to fork, mast reached forward	x ₁ (mm)	221	221	221	221	
1.9	Wheelbase	y (mm)	1460	1460	1460	1535	
Weight	2.1	Service weight (including battery)	kg	3407 ¹⁾	3407 ¹⁾	3407 ¹⁾	3458 ¹⁾
Tyres, chassis	3.1	Tyres: solid rubber, superelastic, pneumatic, polyurethane		Polyurethane	Polyurethane	Polyurethane	Polyurethane
	3.2	Tyre size, front		Ø343×140	Ø343×140	Ø343×140	Ø343×140
3.3	Tyre size, rear ×2		Ø330×100	Ø330×100	Ø330×100	Ø330×100	
3.5	Wheels, number front / rear (x = driven wheels)		1×/2	1×/2	1×/2	1×/2	
3.7	Tread width, rear	b ₁₁ (mm)	1168	1168	1168	1168	
Dimensions	4.1	Tilt of mast/fork carriage forward/backward	α/β(°)	2/4	2/4	2/4	2/4
	4.2	Height, mast lowered	h ₁ (mm)	2315	2315	2315	2315
	4.3	Free lift	h ₂ (mm)	1350	1350	1350	1350
	4.4	Lift	h ₃ (mm)	5000	5000	5000	5000
	4.5	Height, mast extended	h ₄ (mm)	5965	5965	5965	5965
	4.7	Height of overhead guard	h ₆ (mm)	2200	2200	2200	2200
	4.8	Seat height/stand height	h ₇ (mm)	1045	1045	1045	1045
	4.19	Overall length	l ₁ (mm)	2509	2509	2509	2509 ¹⁾
	4.20	Length to face of forks	l ₂ (mm)	1439	1439	1439	1439 ¹⁾
	4.21	Overall width	b ₁ /b ₂ (mm)	1270	1270	1270	1270
	4.22	Fork dimensions	s/e/l (mm)	40/122/1070	40/122/1070	40/122/1070	40/122/1070
	4.23	Fork carriage ISO 2328, class/type A,B		ISO2328 2A	ISO2328 2A	ISO2328 2A	ISO2328 2A
	4.24	Fork-carriage width	b ₃ (mm)	942	942	942	942
	4.25	Distance between fork-arms	b ₅ (mm)	382-746	382-746	382-746	382-746
	4.26	Distance between wheel-arms	b ₄ (mm)	940	940	940	940
	4.28	Reach distance	l ₄ (mm)	490	490	490	565 ¹⁾
	4.32	Ground clearance, centre of wheelbase	m ₂ (mm)	68.5	68.5	68.5	68.5
	4.34.1	Aisle width for pallets 1000 x 1200 crossways	A _{st} (mm)	2871	2871	2871	2889 ¹⁾
	4.34.2	Aisle width for pallets 800 x 1200 lengthways	A _{st} (mm)	2938	2938	2938	2945 ¹⁾
4.35	Turning radius	W _a (mm)	1725	1725	1725	1800	
4.37	Length across wheel arms	l ₇ (mm)	1895	1895	1895	1970	
Performance data	5.1	Travel speed, laden/unladen	km/h	14/14	14/14	14/14	14/14
	5.2	Lift speed, laden/unladen	m/s	0.450/0.480	0.410/0.480	0.360/0.480	0.330/0.480
	5.3	Lowering speed, laden/unladen	m/s	0.510/0.330	0.510/0.330	0.510/0.330	0.510/0.330
	5.8	Max. gradeability, laden/unladen	%	12/15	12/15	11/15	10/15
	5.9	Acceleration time, laden/unladen (0-10m)	s	5.3/5	5.3/5	5.3/5	5.3/5
	5.10	Service brake		Electromagnetic	Electromagnetic	Electromagnetic	Electromagnetic
Electric	6.1	Drive motor rating S2 60 min	kW	6.4 AC	6.4 AC	6.4 AC	6.4 AC
	6.2	Lift motor rating at S3 15%	kW	12.8 AC	12.8 AC	12.8 AC	12.8 AC
	6.3	Battery acc. to DIN 43531/35/36 A,B,C, no		DIN 43531 C	DIN 43531 C	DIN 43531 C	DIN 43531 C
	6.4	Battery voltage, nominal capacity K5	V/Ah	48V /460Ah	48V /460Ah	48V /460Ah	48V /600Ah
	6.5	Battery weight	kg	939	939	939	980 ¹⁾
Addition data	8.1	Type of drive control		MOSFET/AC	MOSFET/AC	MOSFET/AC	MOSFET/AC
		Manufacturer/Type		CURTIS	CURTIS	CURTIS	CURTIS
	10.1	Operating pressure for attachments	bar	150	150	150	150
	10.2	Oil volume for attachments (max)	l/min	65	65	65	65
10.7	Sound level at the driver's ear according to EN / DIN 12 053	dB (A)	72	72	72	72	

1) different battery sizes change these values

★ CE model

